

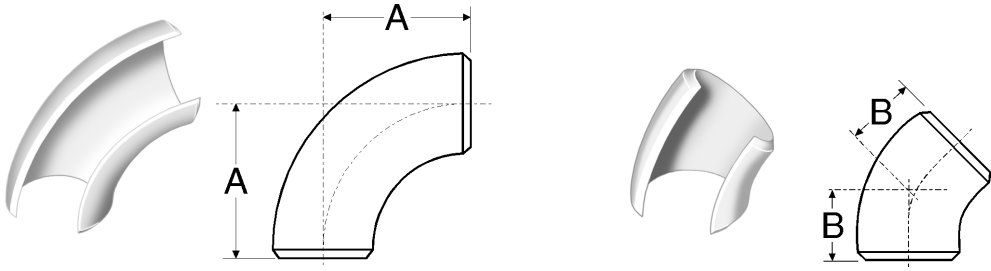





90° and 45° Long Radius Elbows - ANSI B16.9



Dimensions (based on ASME/ANSI B16.9) and example weights for long radius elbows

Nominal Pipe Size	Common		90° Elbow			45° Elbow		
	OD at Bevel 		Dimension 		40S/STD ¹ 	Dimension 		40S/STD ¹ 
	in	mm	in	mm	kg/piece	in	mm	kg/piece
1/2	0.84	21	1.50	38	0.08	0.62	16	0.04
3/4	1.05	27	1.50	38	0.10	0.75	19	0.05
1	1.32	33	1.50	38	0.15	0.88	22	0.07
1 1/4	1.66	42	1.88	48	0.25	1.00	25	0.12
1 1/2	1.90	48	2.25	57	0.36	1.12	29	0.18
2	2.38	60	3.00	76	0.65	1.38	35	0.32
2 1/2	2.88	73	3.75	95	1.29	1.75	44	0.64
3	3.50	89	4.50	114	2.02	2.00	51	1.01
3 1/2	4.00	102	5.25	133	2.83	2.25	57	1.41
4	4.50	114	6.00	152	3.84	2.50	64	1.92
5	5.56	141	7.50	190	6.51	3.12	79	3.25
6	6.62	168	9.00	229	10.1	3.75	95	5.05
8	8.62	219	12.00	305	20.3	5.00	127	10.15
10	10.75	273	15.00	381	36.0	6.25	159	18.0
12	12.75	324	18.00	457	53.0	7.50	190	26.5
14	14.00	356	21.00	533	68.0	8.75	222	34.0
16	16.00	406	24.00	610	89.2	10.00	254	44.6
18	18.00	457	27.00	686	113.0	11.25	286	56.5
20	20.00	508	30.00	762	140.0	12.50	318	70.0
22	22.00	559	33.00	838	170.0	13.50	343	85.0
24	24.00	610	36.00	914	202.0	15.00	381	101.0
26	26.00	660	39.00	991	241.4	16.00	406	120.5
28	28.00	711	42.00	1067	279.9	17.25	438	140.0
30	30.00	762	45.00	1143	321.3	18.50	470	160.5
32	32.00	813	48.00	1219	365.6	19.75	502	183.0
34	34.00	864	51.00	1295	-	21.00	533	-
36	36.00	914	54.00	1372	462.7	22.25	565	231.0
38	38.00	965	57.00	1448	-	23.62	600	-
40	40.00	1016	60.00	1524	571.3	24.88	632	285.5
42	42.00	1067	63.00	1600	629.8	26.00	660	315.0
44	44.00	1118	66.00	1676	-	27.38	695	-
46	46.00	1168	69.00	1753	-	28.62	727	-
48	48.00	1219	72.00	1829	-	29.88	759	-



Notes

- Dimensions quoted in mm are 'Nominal' values from B16.9 (i.e. rounded equivalents of the inch dimensions). Refer to ASME/ANSI B16.9 for additional 'Max' and 'Min' metric dimensions.
- For tolerances see page 6-2.
- 1 Weights are approximate and based on manufacturers' data (where available) for Schedule 40S/Standard fittings. See page 6-6 for further information.

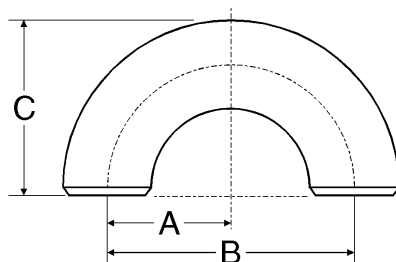
180° Long Radius Returns - ANSI B16.9



Dimensions (based on ASME/ANSI B16.9) and example weights for long radius returns

Nominal Pipe Size	Common		180° Return				40S/STD ¹  kg/piece
	OD at Bevel 		Dimension B		Dimension C		
	in	mm	in	mm	in	mm	
1/2	0.84	21	3.00	76	1.88	48	0.16
3/4 ¹	1.05	27	3.00	76	2.00	51	0.20
1	1.32	33	3.00	76	2.19	56	0.30
1 1/4	1.66	42	3.75	95	2.75	70	0.50
1 1/2	1.90	48	4.50	114	3.25	83	0.72
2	2.38	60	6.00	152	4.19	106	1.30
2 1/2	2.88	73	7.50	191	5.19	132	2.58
3	3.50	89	9.00	229	6.25	159	4.04
3 1/2	4.00	102	10.50	267	7.25	184	5.66
4	4.50	114	12.00	305	8.25	210	7.68
5	5.56	141	15.00	381	10.31	262	13.02
6	6.62	168	18.00	457	12.31	313	20.02
8	8.62	219	24.00	610	16.31	414	40.6
10	10.75	273	30.00	762	20.38	518	72.0
12	12.75	324	36.00	914	24.38	619	106.0
14	14.00	356	42.00	1067	28.00	711	136.0
16	16.00	406	48.00	1219	32.00	813	178.4
18	18.00	457	54.00	1372	36.00	914	226.0
20	20.00	508	60.00	1524	40.00	1016	280.0
22	22.00	559	66.00	1676	44.00	1118	340.0
24	24.00	610	72.00	1829	48.00	1219	404.0
26-48	Long radius returns are not specified for these pipe sizes						

Notes

- For NPS 3/4 the fitting may be furnished with the following dimensions:
B = 2.25 in (57 mm nominal)
C = 1.69 in (43 mm nominal)
- Dimension A = One half of dimension B
- Dimensions quoted in mm are 'Nominal' values from B16.9 (i.e. rounded equivalents of the inch dimensions). Refer to B16.9 for additional 'Max' and 'Min' metric dimensions.
- For tolerances see page 6-2.
- 1 Weights are approximate and based on manufacturers' data (where available) for Schedule 40S/Standard fittings. See page 6-6 for further information.

Short Radius Elbows and Returns - ANSI B16.28

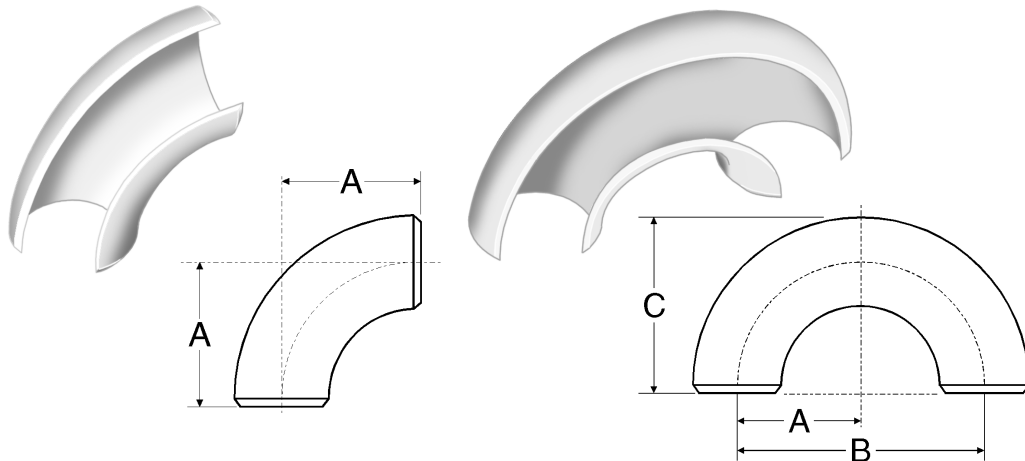

Dimensions (based on ASME/ANSI B16.28) and example weights for short radius elbows and returns

Nominal Pipe Size	Common		90° Elbow			180° Return				
	OD		Dimension A		40S/STD ¹	Dimension B		Dimension C		40S/STD ¹
	in	mm	in	mm	kg/piece	in	mm	in	mm	kg/piece
1	1.32	33	1.00	25	0.12	2.00	51	1.62	41	0.24
1 1/4	1.66	42	1.25	32	0.20	2.50	64	2.06	52	0.40
1 1/2	1.90	48	1.50	38	0.29	3.00	76	2.44	62	0.48
2	2.38	60	2.00	51	0.51	4.00	102	3.19	81	1.02
2 1/2	2.88	73	2.50	64	1.02	5.00	127	3.94	100	2.04
3	3.50	89	3.00	76	1.50	6.00	152	4.75	121	3.00
3 1/2	4.00	102	3.50	89	2.06	7.00	178	5.50	140	4.12
4	4.50	114	4.00	102	3.12	8.00	203	6.25	159	6.24
5	5.56	141	5.00	127	5.28	10.00	254	7.75	197	10.6
6	6.62	168	6.00	152	7.94	12.00	305	9.31	237	15.9
8	8.62	219	8.00	203	17.1	16.00	406	12.31	313	35.5
10	10.75	273	10.00	254	28.6	20.00	508	15.38	391	57.2
12	12.75	324	12.00	305	36.3	24.00	610	18.38	467	72.6
14	14.00	356	14.00	356	45.8	28.00	711	21.00	533	91.6
16	16.00	406	16.00	406	59.4	32.00	813	24.00	610	118.8
18	18.00	457	18.00	457	79.4	36.00	914	27.00	686	158.8
20	20.00	508	20.00	508	97.5	40.00	1016	30.00	762	195
22	22.00	559	22.00	559	-	44.00	1118	33.00	838	-
24	24.00	610	24.00	610	137	48.00	1219	36.00	914	274
26 - 48	Short radius returns are not specified for these pipe sizes									

Notes

- Dimension A = One half of dimension B
- Dimensions quoted in mm are 'Nominal' values from B16.28 (i.e. rounded equivalents of the inch dimensions). Refer to B16.28 for additional 'Max' and 'Min' metric dimensions.
- For tolerances see page 6-2.
- 1 Weights are approximate and based on manufacturers' data (where available) for Schedule 40S/Standard fittings. See page 6-6 for further information.